

# Instruction/Manual for CPS series

## Compact Pressurized Solar Water Heater

**(Please read carefully the manual before use)**

This product has adopted the SOLAR KEYMARK En12976

The manufacturer has quality control system certified by ISO9001: 2015  
This product is approved by the CE standard



Thank you for choosing our CPS58/1800 series solar water heater. You're now having a solar heater with the world's top-level technology, super performance and safe and reliable solar water heater. To bring its full effectiveness to you, please carefully read the User's Manual before installing and using your solar heater and proceed with your installation and use according to the manual.

Please keep your User's Manual for later reference.  
(This manual is exclusively for CPS58/1800 series pressure solar water heater.)

# Content

I. Features.....	1
II. Method of Installation.....	2
III. Using Method and Notices.....	9
IV. Common Failures and Troubleshooting.....	9

# I. Features

## 1. Advanced technology:

The core parts of the solar water heater are heat pipe vacuum tube and stainless steel inner tank, which involve numerous national patented technology. The heat pipe vacuum tube with advanced technology in gathering solar energy features water-tightness, high heat absorption, independent heat supply, fast energy output, wide scope of application and long working life.

## 2. Low heat loss:

With imported polyurethane foam en-bloc high pressurized, which is of high density and strength, the solar heater has excellent heat insulation.

## 3. Superb process technology:

The pressurized inner water tank is made of special metal, formed up with advanced punching technology and auto non-electrode instead of welding technology. A special silicate is sintered by high temperature to the inner tank's walls, forming a special protection layer featuring of anti-leakage, anti-rust/erosion and anti-scaling, thereby effectively preventing leakage between the water tank and the heat-gathering tubes and ensuring the water cleaning.

## 4. Low heat diffusion:

- Connections to water outlet, sensor and electrical auxiliary element are all underneath the water tank.
- Heat diffusion at all connections is greatly reduced, virtually eliminating heat diffusion by convection, resulting in high heating efficacy.
- Thorough draining of hot water in the tank, effectively enhancing the volume utilization rate
- Air vent/overflow outlet is led indoor through pipeline, easy to monitor and water inlet can be fitted with high-level single-line valve to realize automatic water feeding, stopping water feed when full

## 5. Easy for functional extension:

This solar water heater is fitted with feed-in water connection, overflow connection, and connections for computerized controller and electrical element. The user can have a number of options depending on his actual needs.

- Connections for sensor and electrical element are plugged
- Sensor is an accessory to the computerized controller and is sold together with computerized controller, electrical element and electromagnetic valve as accessories.

## II. Method of Installation

Attention!

- Qualified professionals must do installation of the solar heater  
  
Location of installation must be flat without obstruction in the front,  
  
which would reduce heat gathering efficiency.
- Installation foundation of the solar water heater should bear twice the weight of water container capacity.
- Installation must be secure and stable to prevent damage and accident
- It is recommended that the hot/cold water pipelines should be with adequate insulation in order to prevent freezing in winter times, or it will affect the normal use of the heater.
- Before installation be sure to check the water tank for alien matter and flush it clean with water.

# 1.Supporting stand assembly (see Fig 1, Fig 2):

- Assemble Right and Left tank supports, Right and Left front pillars, and fixing feet by M6\*12 and M6 screws.
- Assembly rear bars, rear pillars, side short bars, side long bars, etc by M6\*12 and M6 screws.
- Assembly reflecting plates and their fixing plate, middle horizontal bar and front bar by M6\*10 screws.

Attention! The flat side of the fixation foot must be parallel with the end. Attention! Foundation must be level and fastening must be firm.

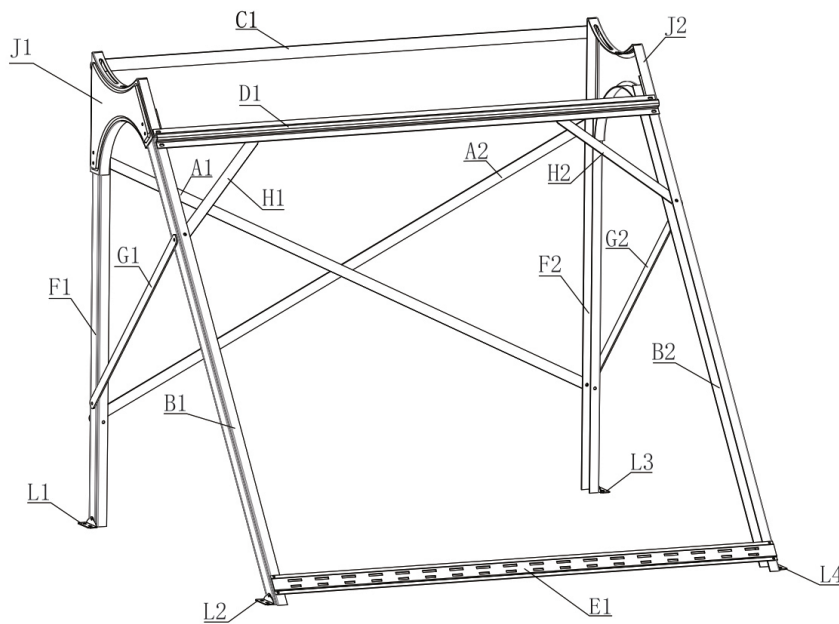

Fig.1

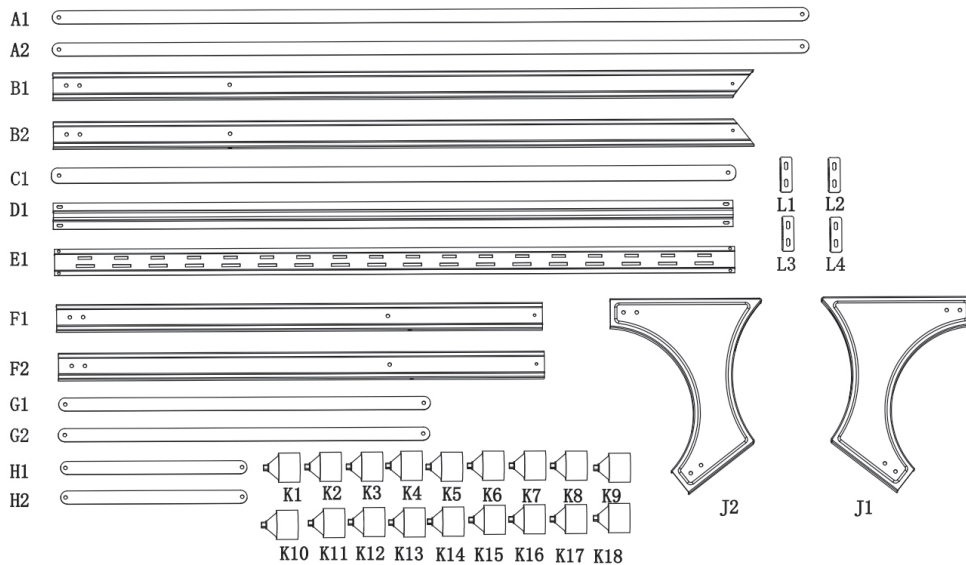

Fig.2

## 2. Installation of water tank and heat pipe vacuum tube

A. Set the water tank symmetrically on the supporting frame and secure with 4 sets of M8 nuts, please see (Fig 3)

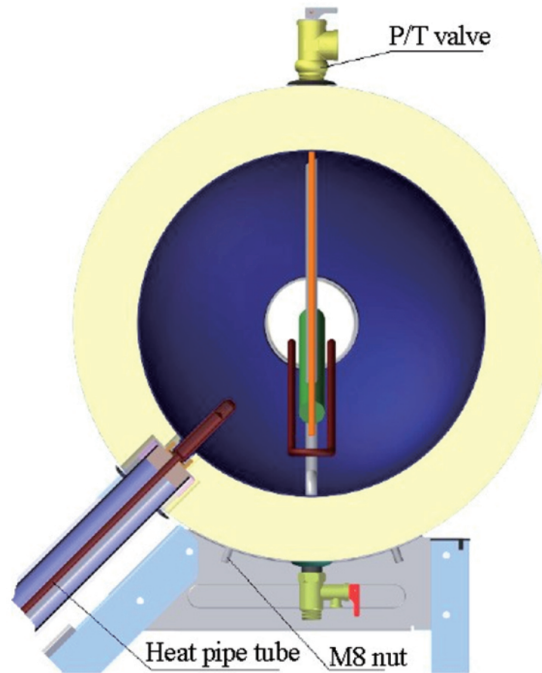

Fig.3

B. Installation of heat pipe vacuum tube to the water tank:

Run in the upper protection ring at the condensing end of the heat pipe vacuum tube, apply heat conducting silicon grease to the condensing end of the tube and then insert the condensing end of the inner tube into the water tank's heat conducting sleeves, see (Fig 4, Fig 5).

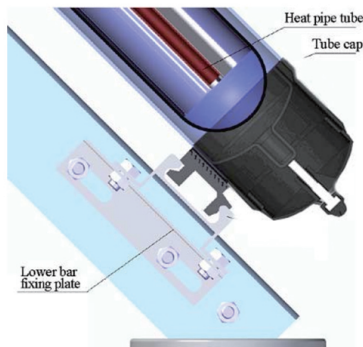

Fig.4

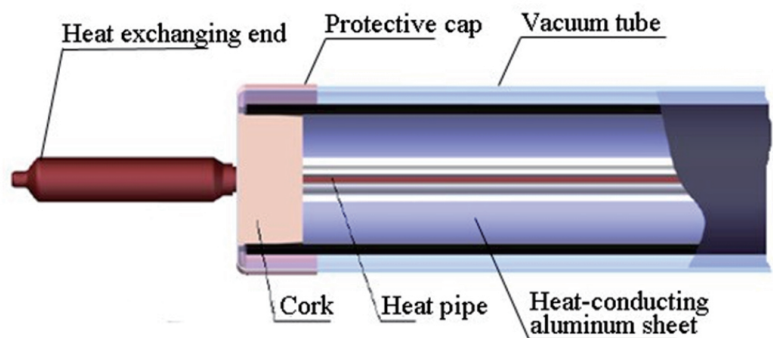

Fig.5

**Attention!**

- ▲ Apply enough silicon grease to the top of the condensing end
- ▲ Make sure that the condensing end of the heat pipe vacuum tube is in close connect with heat conducting sleeve, free of any clearance
- ▲ Before installation, make sure that heat pipe vacuum tube is not exposed in sunlight for a long time, in case that the condensing end gets scorch and expand and can not inserted in the heat conducting sleeve

**4. Installation of pipeline**

Please pay attention to the following when doing the installation: see (Fig 6)

**5. Installation of the adjustable tail seat:**

Run in the tail seat retention ring at the tail end of the heat pipe vacuum tube and fit the tail seat retention ring to the lower horizontal linkage rod as shown in Fig.6. Then fit the tail seat adjusting ring to the retention ring by turning the former; while turning, apply appropriate force to lift the heat pipe vacuum tube upward so that there is no room for it to move up/down.

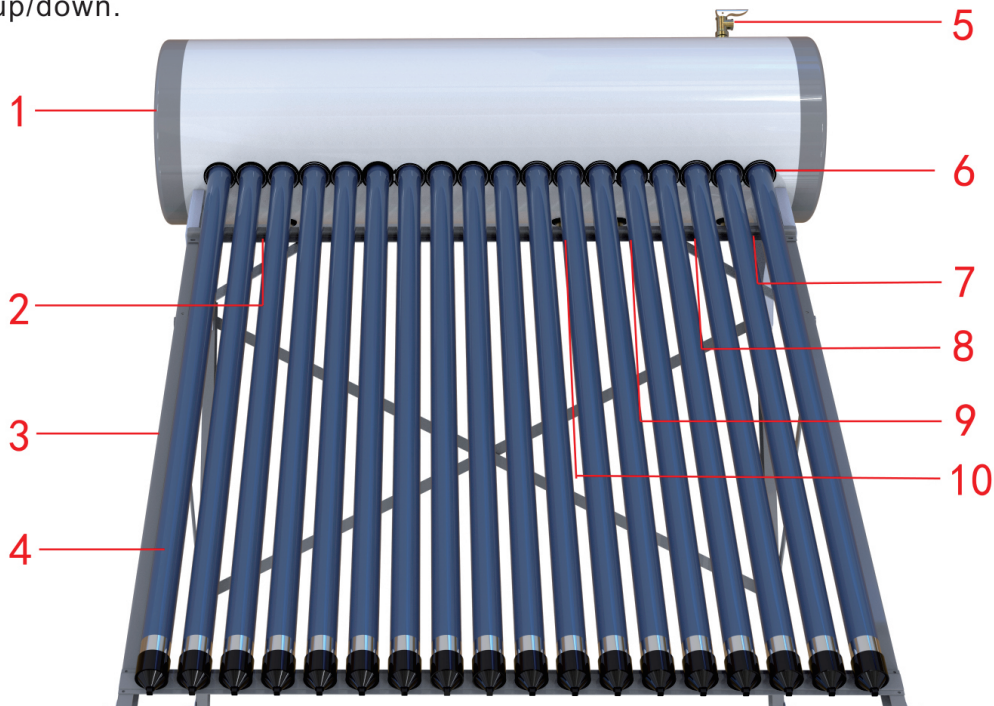
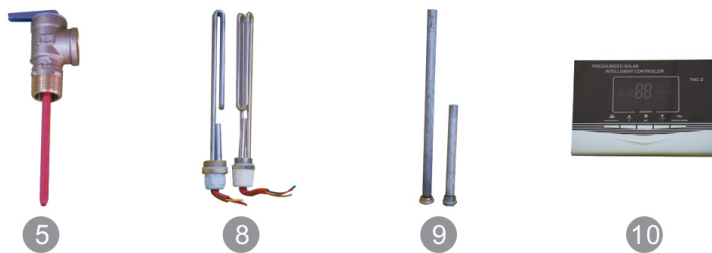

Fig.6



1	Solar water heater Tank	6	Anti-dust Ring
2	Inlet for cold water	7	Outlet for hot water
3	Frame	8	Electric Heater Hole
4	Vacuum Tube	9	Magnesium Rod Bar Hole
5	Air Vent	10	Sensor Hole

- ① There are G1/2" screw thread for all the joints of tank's cold and hot water, and the joint of P/T valve is G3/4"
- ② Layout should be according to the pipe installing regulation.
- ③ One- way safe draining valve should be installed at cool water inlet joint(Fig.7), which should be connected with air and towards downside, the position cannot be too deep, normally 10mm.
- ④ The outside pipes need over 50mm warm-keeping to avoid being frozen in winter.
- ⑤ While connecting pipes, do not use too big force. (Fig.8)

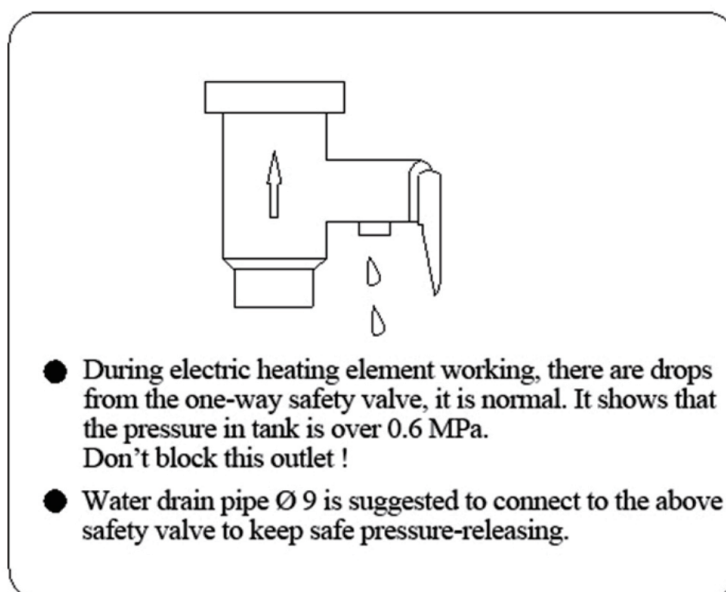

Fig.7

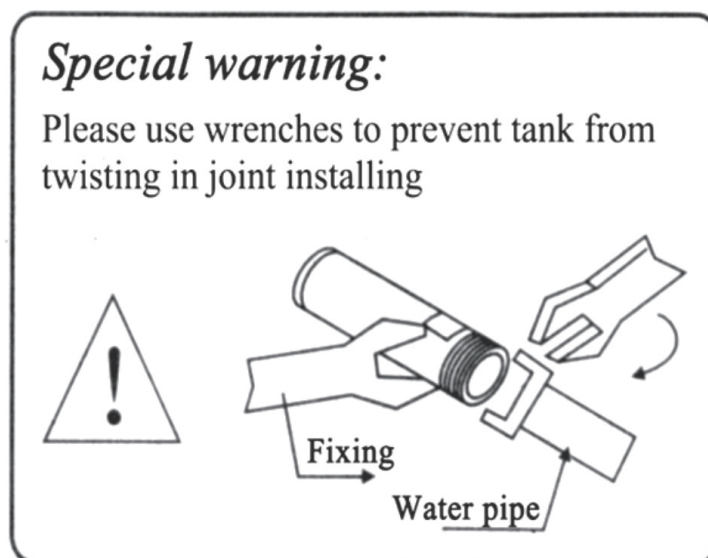

Fig.8

- ⑥ If solar water heater is higher than the around buildings, lightening rod is needed. The lightening rod of building should be 50cm higher than the water tank and the interval space not less than 30mm.

#### 4. Installing micro controller:

##### Caution

- ① The socket and plug should be connected well.
- ② If auxiliary electric heating system installed, do connect the live wire, null wire and ground wire correctly with power-leakage protection plug. The socket should be connected to ground. (Fig.9)

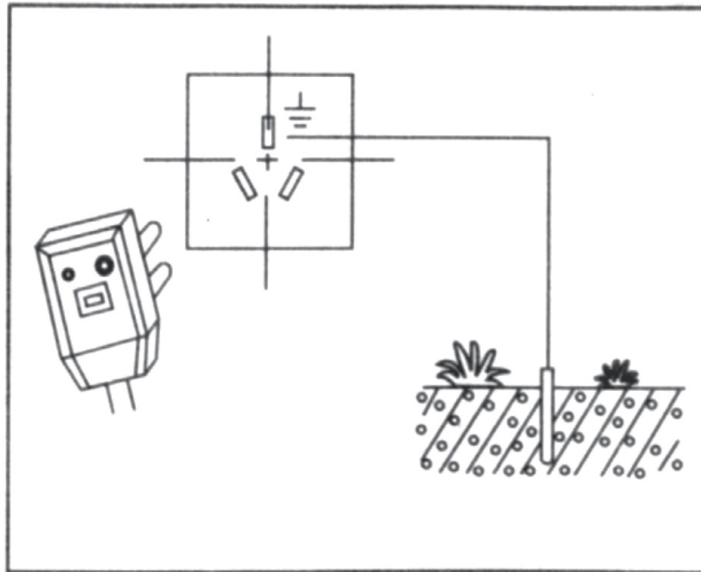

Fig. 9

- ③ Use tri-wire plug of safe protection, and the rated current value of socket  $\geq 10A$
- ④ Safe measures should be taken and layout to specification.
- ⑤ Installing micro controller (Fig.10) Details see the manual of Micro Controller. Layout sees (Fig.10) and (Fig.11), See page 11 for details.

Correctly use micro controller. Please read the manual before using. Details see its manual.

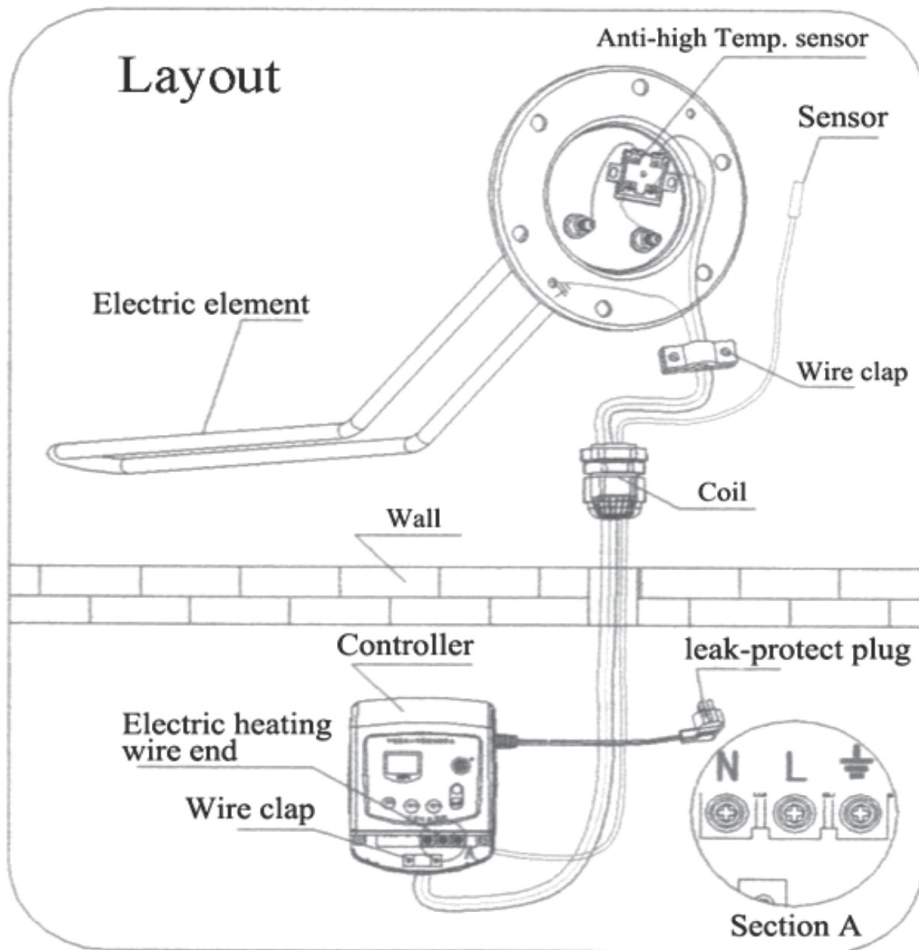

Fig.10

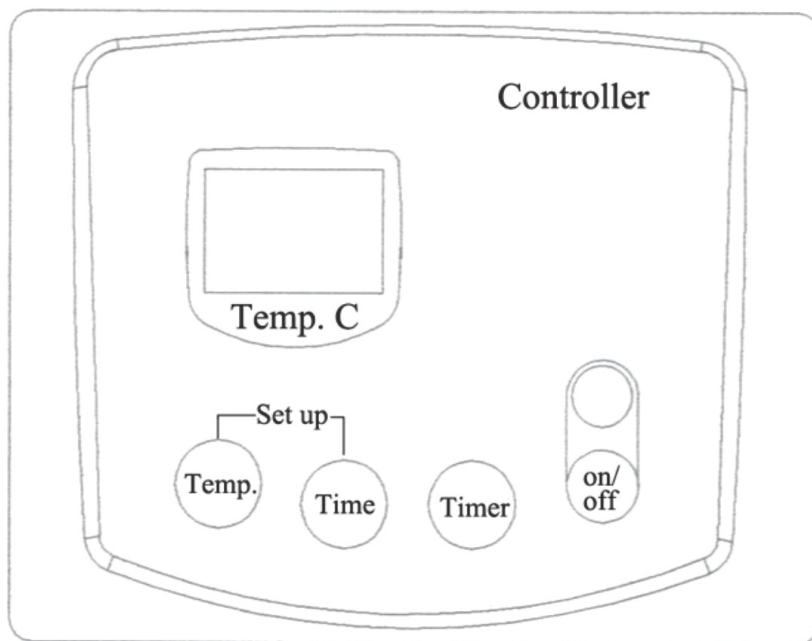

Fig.11

### III. Using Method and Notices

**Caution:**

The solar collector tube should face south with nothing blocked, and supports reliable to anti-strong wind.

- ① Filling water: The heater is filled water by pressure and free of filling device (Fig.6), water will be automatically filled till fullness and then stops.
- ② Using water: Water can be used under pressure.

### IV. Common Failures and Troubleshooting

#### Trouble shooting

Symptoms of trouble	Causes	Way of removing
No self check at switch on, no display or confused display	Poor contact at power input plug	Unplug power, and check the plug and plug in again
Display is “_____”	Poor contact of sensor plug in or wire broken	Plug in again or replace
Leakage protection’s power indicator not lit up	Leakage protection is activated	Check the cables and electrical heating tubing for power leakage
No heating and no temperature-rise, heating indicator is constantly on	Electrical heating tube is damaged Temperature reaches the set value	Replace the heating tube Set water temperature at a higher value
Water in the tank not hot	Heat gathering tubing covered up by dust etc	Dust removal, remove covering
	Low solar radiation	Let the heater work 2—3 days before using
	Heat gathering tubing damaged, low absorption	Replace heat gathering tubing
	Scaling on the heat conducting sleeve	Remove the scaling
No hot water or no water comes out	Low tap water pressure	Boosting the pressure
	Feed in valve not shut properly or damaged one way safety valve, resulting in hot water returning	Replace the valve
	Leakage in water tank	Replace tank or send for repairs
	Freezing of outdoor plumbing	Unfreezing or send for repair crew
	Pipeline fallen off or valve failure	Send for repairs

